

PARTS LIST			
ITEM	QTY	PART NUMBER	DESCRIPTION
1	1	---	MOUNTING BOARD
2	1	---	12 PIN TERMINAL STRIP
3	1	---	BUS BAR
4	1	---	HARNESS, RELAY- HSR/MSR/LSR/CR/CLR
5	3	01 000 194	RELAY, 40A
6	2	01 000 807	RELAY, 70A-HD MANUFACTURER: TE CONNECTIVITY PART NUMBER: V23134-J1052-X439
7	15	---	SCREW, #8-32 x 3/8 CROSS RECESSED
10	2	---	SCREW, #8-32 x 5/8 CROSS RECESSED
11	2	---	WASHER, #8 PLAIN
12	1	60 001 382	BRKR, 20 AMP
13	1	60 001 418	BRKR, 10 AMP
14	2	60 001 384	BRKR, 40 AMP
15	2	---	WIRE TIE
16	1	---	BATTERY LABEL
19	1	---	SPRAY, ANTI-CORROSION
20	1	01 000 458	BRKR, 50 AMP
21	1	---	LABEL, 12 POSITION TERM STRIP
22	1	---	LABEL, PART NUMBER, REV
23	44	---	10-32 kep lock nut

PART NO. 01 000 630

NOTES:

- 1) SPRAY WITH ANTI-CORROSION SPRAY.
- 2) ALL DIMENSIONS +/- .0625 UNLESS OTHERWISE SPECIFIED.
- 3) PART MUST BE LABELED WITH PART NUMBER.
- 4) ALL RELAYS MUST BE LABELED PER SCHEMATIC.
- 5) MUST HAVE BATTERY LABEL.
- 6) EACH RELAY IS TO HAVE DIELECTRIC GREASE ON EACH TERMINAL.
- 7) REF: PD023 11 006

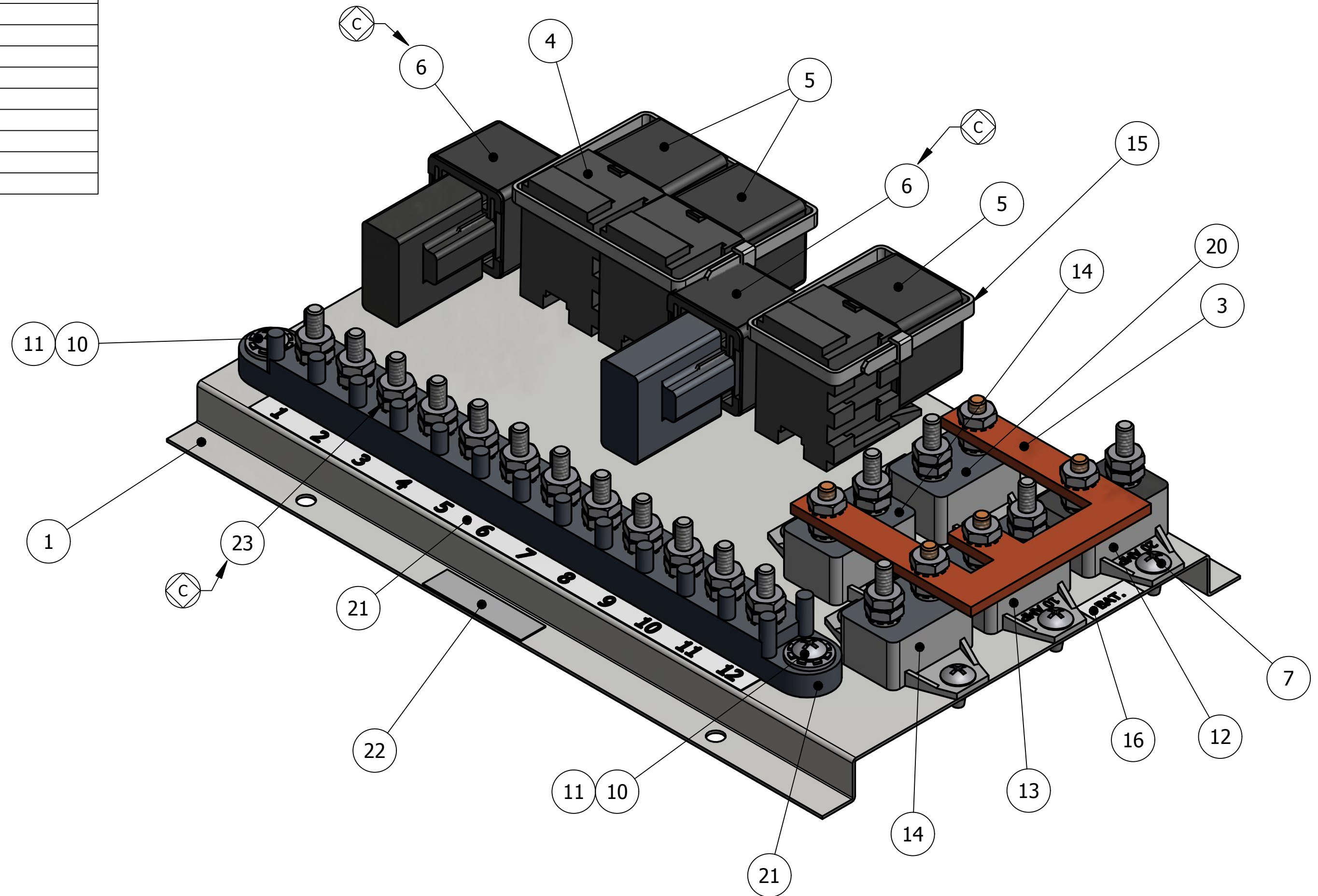

PROPRIETARY & CONFIDENTIAL. UNPUBLISHED WORK COPYRIGHT PRO AIR LLC. PRO AIR, LLC CLAIMS PROPRIETARY RIGHTS IN THE MATERIAL DISCLOSED HEREON. NEITHER THIS DRAWING NOR ANY REPRODUCTION OR PORTION THEREOF MAY BE DISTRIBUTED OR USED TO MANUFACTURE ANYTHING SHOWN HEREON WITHOUT PERMISSION IN WRITING FROM PROAIR, LLC.

REV. C

C	14-171	CR 10GA BLACK WIRES TO 8GA RED WIRES SPECIFY 70A RELAY TO BE TYCO V23134-J1052-X439	DAS	12/16/14	SIGNATURES DRAWN MRM	DATE 7/6/2011	 28731 C.R. 6 ELKHART, IN 46514	TITLE: RELAY BOARD, EZ 3, 4, 5, 6	PART NO. 01 000 630
	B	14-019	ADDED ITEM 22, PART NUMBER LABEL	MRM	1/22/14	CHECKED RAI		12/17/2014	USAGE:
A	11-145A	RELEASED TO PRODUCTION	MRM	7/15/11	APPROVED				SHEET 1 OF 3
REV	ECR#	REVISION DESCRIPTION	BY	DATE					

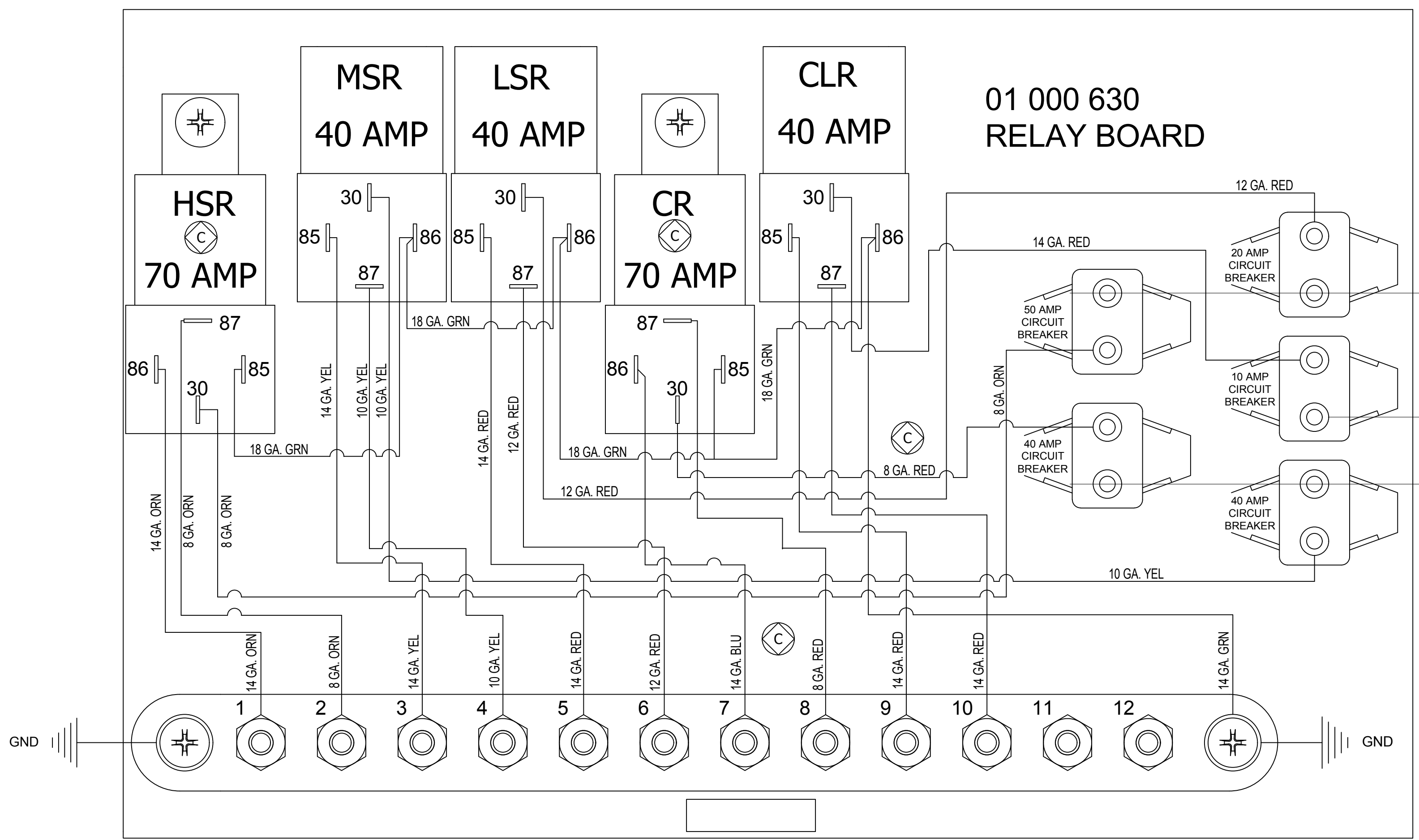

Ⓢ
 REV C NOTES: SWAPPED THE COIL TERMINAL WIRES SUCH THAT THE GROUND GOES TO TERMINAL 85 AND THE SWITCHED 12V GOES TO TERMINAL 86 ON THE 70A RELAYS, (HSR & CR).

PROPRIETARY & CONFIDENTIAL. UNPUBLISHED WORK COPYRIGHT PRO AIR LLC. PRO AIR, LLC CLAIMS PROPRIETARY RIGHTS IN THE MATERIAL DISCLOSED HEREON. NEITHER THIS DRAWING NOR ANY REPRODUCTION OR PORTION THEREOF MAY BE DISTRIBUTED OR USED TO MANUFACTURE ANYTHING SHOWN HEREON WITHOUT PERMISSION IN WRITING FROM PROAIR, LLC.

REV. C

C	14-171	CR 10GA BLACK WIRES TO 8GA RED WIRES SPECIFY 70A RELAY TO BE TYCO V23134-J1052-X439	DAS	12/16/14	SIGNATURES	DATE	 28731 C.R. 6 ELKHART, IN 46514	TITLE:	RELAY BOARD, EZ 3, 4, 5, 6	PART NO.	01 000 630
	B	14-019	ADDED ITEM 22, PART NUMBER LABEL	MRM	1/22/14	CHECKED		RAI		12/17/2014	USAGE:
A	11-145A	RELEASED TO PRODUCTION	MRM	7/15/11	APPROVED					SHEET 3	OF 3
REV	ECR#	REVISION DESCRIPTION	BY	DATE							